

BluBox™ MBR

Rapidly deployable, highly reliable treatment and reuse systems.

The Leading Packaged MBR SOLUTION

- Complete wastewater treatment system in a containerized package.
- Small footprint.
- Can handle higher loading than other biological treatments.
- Modular and scalable.
- Operator friendly.
- Rental and leasing options including lease to own.
- Fastest delivery in the industry.

QUICK FACTS

- ➔ Standalone solution with onboard capacity up to 75,000 GPD, with expansion capabilities based on project requirements.
- ➔ Pre-built, pre-tested, and integrated with standardized process components including membrane modules.
- ➔ Modular and scalable from 30K-300K with options up to 2 MGD.
- ➔ Meets Build America, Buy America standards.

Is this system right for you?

New complete plant, expansion of existing plant, short-term lease for emergency/interim treatment solution.

CONTAINERIZED MBR PROCESS

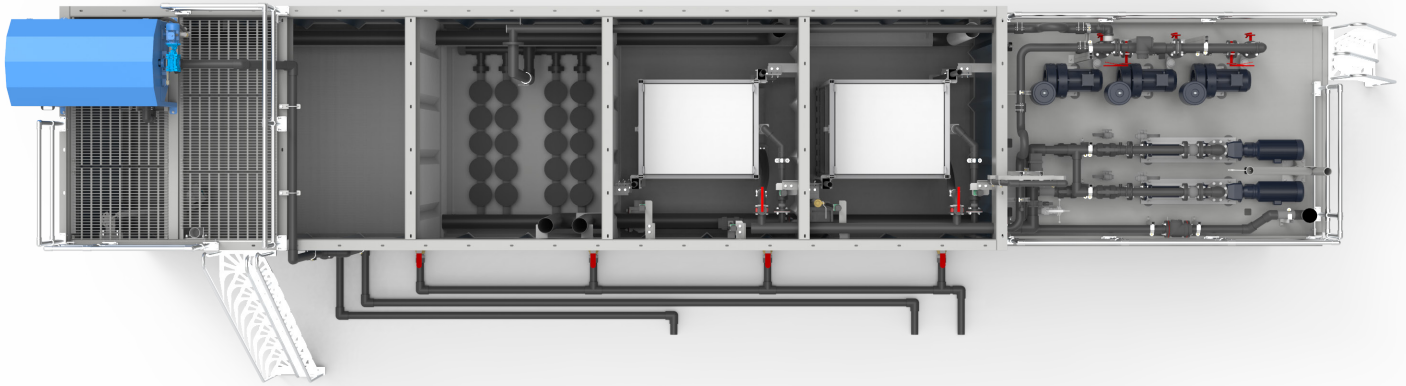

Nominal Biological Treatment Capacity	Up To 75,000 GPD
---------------------------------------	------------------

Maximum Hydraulic Capacity Per Unit (Peak Factors Vary)	Up To 150,000 GPD
--	-------------------

Equalization, Waste Solids Storage	Optional
------------------------------------	----------

Tankage Materials	Coated Carbon Steel
-------------------	---------------------

Typical Ready To Ship Time (Inventory Dependent)	4-6 Weeks
---	-----------

Membrane Type Available	UF/MF
-------------------------	-------

Site Installation Required	Minimal
----------------------------	---------

Tank Base Length X Width X Height	45' x 8.6' x 12'
-----------------------------------	------------------

Loading Capacity	12,000 mg/L BOD/COD
------------------	---------------------